

CP SERIES MACHINE FOOTPRINTS

Formerly Salwasser L Models

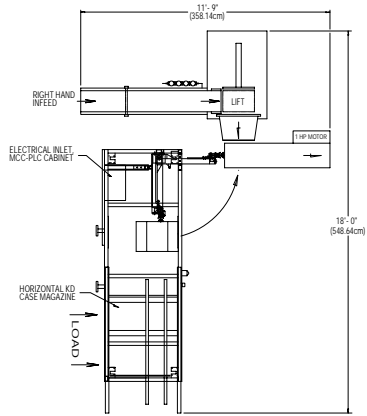

CP 200

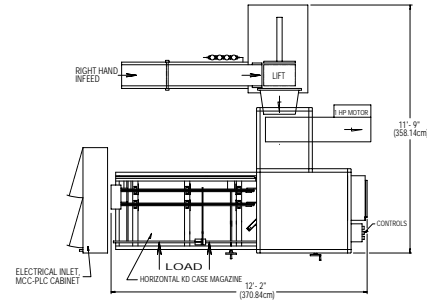

CP 400

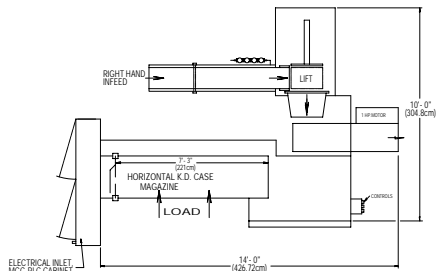

CP 430

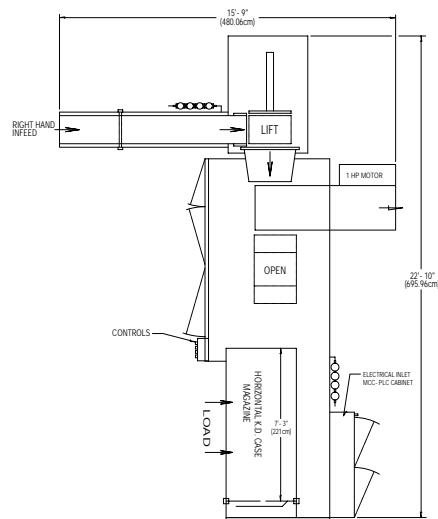

CP 450

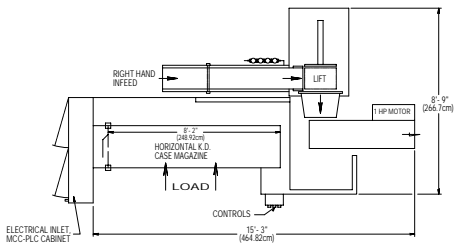

CP 440



A DOVER COMPANY

1949 East Manning Avenue • P.O. Box 548 • Reedley, California 93654
 Phone: (559) 638-8484 • Fax: (559) 638-7478 • Toll Free USA: (800) 344-8951
 E-mail: info@swfcompanies.com • Web Site: www.swfcompanies.com



CP SERIES CASE OPENER/ POSITIONER

Fully Automatic Case Openers and Positioners

- Up To 15 Cases Per Minute
- Positive Case Opening
- Full Operator Safety
- Quick Changeover
- Easy Loading Magazines
- Customized Designs
- Operator Friendly Low Level KD Case Magazines
- Left or Right Hand Construction
- Horizontal or Vertical Case Opening & Flap Folding



CP 440



A DOVER COMPANY

CP CASE OPENERS/POSITIONERS

SWF Companies' CP models are fully automatic case opening and positioning systems designed for easy integration with a wide variety of case loaders. The CP models open KD cases and position them onto the loading tube/funnel of a case loader at speeds up to 15 cases per minute, eliminating manual

case setup and improving productivity. The case loaders can be new or existing units, built by **SWF** or other manufacturers. Products handled typically include bathroom tissue, napkins, cookies, cereals, frozen foods pharmaceuticals, paper towels and a host of other items.

CP FEATURES AND OPTIONS

Standard Features:

- Up to 15 Cases per Minute
- Operator Friendly Low-Level KD Case Magazines
- Positive Case Opening
- PLC Controls
- Quick Changeovers
- Compact Designs
- Low Maintenance
- Full Operator Safety
- Horizontal or Vertical Opening & Flap Folding
- Rugged Construction

Options:

- Touch screen operator interface with multiple screens and message panels.
- Automatic bundle loading of case blanks in the magazine and extended case blank capacity magazines.
- Centralized grease blocks or automatic lubrication systems.
- Various product handling devices, including converging, diverging, accumulating and positioning devices.
- Many other features and options are available to customize machines to meet individual requirements.

CP SERIES MODELS

CP 200 -Low cost, low speed opener/positioner. Opens both horizontal and vertical cases.
 CP 400 -Low cost, low speed opener/positioner. Opens both horizontal and vertical cases.
 CP 430 -Medium speed opener/positioner with floor level KD case magazine. Opens both horizontal and vertical cases.



CP 200



CP 430

CP 440 -Low speed opener/positioner with floor level KD case magazine. Opens both horizontal and vertical cases.

CP 450 -Inline low speed opener/positioner with floor level KD case magazine. Opens both horizontal and vertical cases.

CASE OPENING & TUCKING SEQUENCE

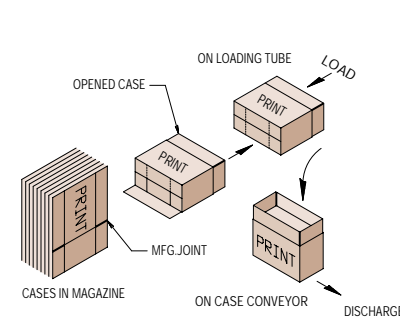

Horizontal Case Opening Sequence

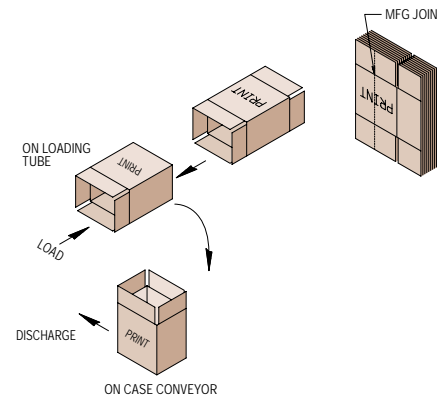

Vertical Case Opening Sequence (CP450)

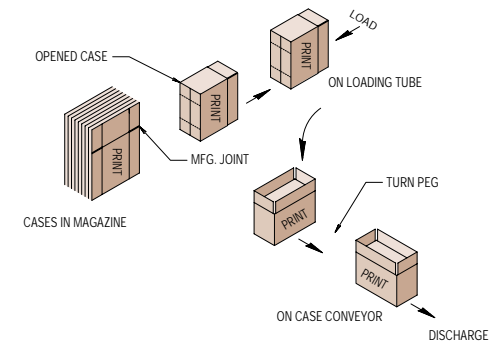

Vertical Case Opening Sequence

ACP ATTACHMENT

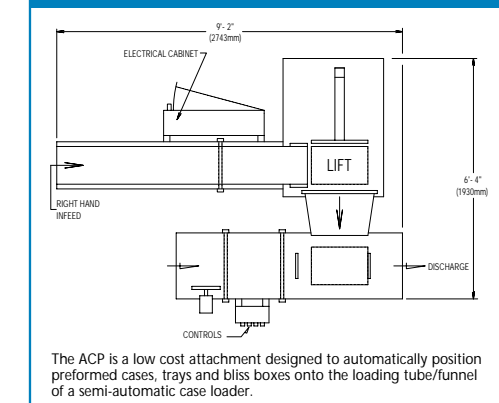

MACHINE SPECIFICATIONS

Model	Maximum Speed	Standard Blank Capacity	KD Case Magazine Elevation*	Electrical Requirements
CP 200	12	250	32" - 45"	115 VOLT, 1 Phase, 60 Hz
CP 400	12	250	32" - 45"	115 VOLT, 1 Phase, 60 Hz
CP 430	15	300	15" - 26"	230/460 VOLT, 3 Phase, 60 Hz
CP 440	10	300	15" - 26"	230/460 VOLT, 3 Phase, 60 Hz
CP 450	12	250	15" - 26"	230/460 VOLT, 3 Phase, 60 Hz

*KD case magazine elevations vary depending on case size and elevation of case packer/loader.