

# TF 600VK TrayMatic

Options



A **DOVER** COMPANY

The following are the standard illustrations and parts lists for the options for a TF 600VK machine.

*Proud manufacturers of the following packaging machinery lines:*

*SWF Machinery • Dyna-Pak • McDowell • Padlocker • Salwasser • Tri-Sterling • Yakima Wire*

1949 E Manning Ave • Reedley, CA 93654 • Tel. (559) 638-8484 • Fax. (559) 638-7478 • Toll Free (800) 344-8951

Web: [www.swfcompanies.com](http://www.swfcompanies.com)

© 2005 By SWF Companies, Inc.

**This copyrighted document is the property of the SWF Companies Inc. and all rights are reserved. Use of the document is licensed to the designated Licensee solely in connection with the operation of the SWF machine referenced in this document. Dissemination to any third party, or other unauthorized use of any portion of this document, or of the information contained herein, is strictly prohibited. ®**

# Table of Contents

---

Table of Contents .....	3
Spare Parts Ordering .....	5
Safety .....	7
Equipment Safety .....	7
Guards .....	7
Emergency Stop.....	7
Power Disconnect.....	8
Precautions and Warnings .....	8
Lockout Information.....	9
Main Power Panel .....	9
Power Disconnect Switch .....	9
Safety Features .....	9
Options.....	11
“V” Belt Vari-Drive Assembly:.....	12
Vari Speed Control Knob Assembly .....	14
Large Capacity Glue Pot (Kwik-Change).....	16

**Thank you for choosing packaging equipment from SWF Companies.**



The equipment you purchased will provide years of productive service, producing a high return on your investment. Your equipment was thoroughly tested for proper operation prior to shipment.

Before unpacking and installing your new equipment, please read this manual. It is your guide to safe installation, productive operation, and effective maintenance. We recommend you keep this manual available for future reference.

Be aware that our commitment to you does not end with your purchase. That is just the beginning. The safe and efficient operation of your SWF equipment is very important to us as a machine manufacturer.

Training and parts distribution are an integral part of our business. SWF service technicians have spent months of in-plant hands-on training, prior to servicing our worldwide installations. Their expertise on our equipment is as close as your telephone. Given sufficient notice, service technicians are available for dispatch to your installation. We also maintain an extensive inventory of spare parts. We typically can have the parts you need in your plant the next working day.

**The entire family of SWF Companies, a Dover Diversified Company is committed to the success of your operation and thanks you again. Feel free to call us anytime.**

SWF Companies is committed to providing product manuals that meet the needs of its valued customers. We invite you to offer suggestions for continued improvement of this manual.

<p>To contact SWF Companies, Inc. Parts and Service</p> <p>Local .....(559) 638-8484</p> <p>Toll-Free.....(800) 344-8951</p> <p>Fax.....(559) 638-7478</p>	<p>Published by:</p> <p>SWF Companies, Inc.</p> <p>1949 E Manning Ave</p> <p>Reedley, CA 93654</p> <p>2003</p>
--	--

# Spare Parts Ordering

---

For General Information and Ordering Parts Contact:



1949 E Manning Ave • Reedley, CA 93654  
Tel. (559) 638-8484 • Fax. (559) 638-7478 • (800) 344-8951  
Web: [www.swfcompanies.com](http://www.swfcompanies.com)

Before contacting SWF Companies for parts or service, please know the machine model and serial number of your equipment. Locate the serial number, usually noted on a metal tag riveted to the frame. You need this serial number when ordering parts:

- 1) Included with this manual is a complete set of assembly drawings to assist you in locating your part. Locate the assembly the part is ordered for.
- 2) Once you have the assembly drawing, locate the item number of the part you want to order and write down the part number from the bill of materials.
- 3) When calling the SWF Companies for parts, have the following information ready:
  - (a) Machine model and serial number (Example: CE-300 TA, s/n CG00001 ).
  - (b) The assembly drawing number and description (CG-000150, vacuum lift arm).
  - (c) The item number, part number and description (item #16, 201806, male rod end bearing).

Following the above procedure assists us in supplying you with the correct parts for your machine and eliminates misunderstandings between your purchasing agent and our parts department.

The contact information below may be subject to change. Please refer to our website at: [www.swfcompanies.com/cs1.html](http://www.swfcompanies.com/cs1.html) for updated service department information.

## **General Information**

1949 E Manning Ave • PO Box 548 • Reedley, CA 93654  
559-638-8484 • 559-638-7478 (Fax)  
800-344-8951 (USA Toll Free)  
Web: [www.swfcompanies.com](http://www.swfcompanies.com)

## **Parts Sales Department**

800-344-8951 (USA Toll Free)  
559-638-7478 (Fax)  
[parts@swfcompanies.com](mailto:parts@swfcompanies.com)

***Technical Service***

559-638-8484 ♦ 559-638-7478 (Fax)  
800-344-8951 (USA Toll Free)  
Service and Support 24/7 Mobile: 559-250-6046

Marty Silveiria, Keith Henvit, Alan Eastep

***Machine Upgrades and Conversions***

1949 E Manning Ave ♦ PO Box 548 ♦ Reedley, CA 93654  
559-638-8484 ♦ 559-638-7478 (Fax)  
800-344-8951 (USA Toll Free)

Tim Gonzales: [tgonzales@swfcompanies.com](mailto:tgonzales@swfcompanies.com)

Irene Hill: [ihill@swfcompanies.com](mailto:ihill@swfcompanies.com)

Frank Blankenship: [fblankenship@swfcompanies.com](mailto:fblankenship@swfcompanies.com)

# Safety

Machinery can be hazardous if safety precautions are not followed. This section deals with safety rules and practices that **MUST** be followed for safe operation of the machinery and to prevent accidents from occurring. All operators and maintenance personnel working on or near SWF Companies' machinery should be fully informed and correctly supervised concerning safe and correct machine operation.

All equipment manufactured by SWF Companies is safety tested before shipping from the plant. Records of machine safety tests are filed at the plant. Safety equipment on SWF machines is also tested in the customer's plant when a SWF Service Representative assists in starting up newly installed machinery.

Be sure all supervisors read and fully understand the contents of the operation portion of this manual, with particular attention to safety precautions. Verify anyone working on or around the machine has read and fully understands the safety precautions noted throughout this manual.

- The responsibility for safe machine operation is shared among the employer, supervisor, operator, attendant, and all maintenance personnel working with the machine. Read the instructions. Re-read them periodically.
- Continually evaluate accident prevention procedures. This means ALL potential hazards must be identified, and eliminated or safeguarded. Along with creating safe conditions, all employees should follow safe practices.
- If any questions ever arise regarding the safe operation or maintenance of this machine, immediately contact:

SWF Companies  
1949 E. Manning Ave  
P.O. Box 548  
Reedley, CA 93654-0548

Phone: 559-638-8484  
Fax: 559-638-7478



## Equipment Safety

SWF machinery uses many safety devices designed to prevent injury to personnel who come in contact with the machine. All safety switches and devices should be checked daily to ensure that they operate properly. Any removal or alteration of these devices can result in serious injury.

### Guards

Guarding includes sheet metal fixed guards or transparent polycarbonate plastic. Hinged or sliding guard doors are installed in areas requiring easy access. Doors with safety interlocks automatically stop the machine by disconnecting the electrical power and dropping air from the machine when the door opens.

The electrical power and air pressure remain off until all guard doors are closed and the start-up sequence is followed.

### Emergency Stop

Emergency stop controls or "E-STOP" is a lighted push/pull button installed on each operator control panel. The pulled-out (on) position allows for operation. The pushed-in (off) position of any e-stop button causes a complete machine shut-down by shutting off power and air to the machine.

The dump valve releases air pressure, causing the air pressure switch to open and shut off the master control relay. The machine remains shut down until all emergency stop buttons are reset and the start-up sequence is performed.



**WARNING:** Do not use the e-stops to prevent inadvertent starting of the machine. Always perform power and air lock out procedures on the main disconnect or designated auxiliary disconnect before reaching into the machine.

### *Power Disconnect*

The DISCONNECT SWITCH or CIRCUIT BREAKER mounts on the main electrical cabinet and shuts off electrical power to the machine. There may be additional remote disconnect switches mounted elsewhere on the machine.

To open the electrical cabinet door, first move the disconnect switch to the **off** position.

**WARNING:** Always use the lockout feature of the disconnect switch to ensure the electrical power remains off during any maintenance or repair work.

Not all disconnect switches shut off all power. Some switches only shut-off power to a particular area or to certain components. Never assume any single disconnect switch shuts-off ALL power to the machine. Refer to the electrical schematics for specific information.



## Precautions and Warnings

Injury or loss of limbs may result if this machine is improperly operated or maintained. Please note the following precautions:

- ⚠ Never adjust, repair, clean, or clear a jam without turning the power off. To shut down the power, turn the disconnect switch to the off position and lock it in the off position.
- ⚠ Do not operate this machine without the guards in place.
- ⚠ Turn off the power before removing or opening any guards. Turning off the power means locking the power disconnect switch in the off position.
- ⚠ Hot surfaces! Severe burns result from the improper handling of the hot melt glue system. Wear proper clothing and high temperature gloves when cleaning or repairing the hot melt glue system.
- ⚠ Replace all broken or worn parts immediately. Check and tighten all bolts and screws.
- ⚠ High voltage electrical equipment – authorized personnel only.
- ⚠ Turn off the power when the machine is not in use.
- ⚠ This machine starts automatically in the ‘auto’ position when the downstream control contact and/or time delay attachment is used.
- ⚠ Always wear proper clothing during operation of heavy-duty machinery.

SWF Machinery endeavors to comply with OSHA standards. You, however, are the most important part of safe equipment operation. In order to provide for your safety, you should be knowledgeable and put into practice the following:

- ➡ Always know the purpose of the control buttons and selector switches before operating any equipment.
- ➡ Always test the emergency stop and a normal cycle stop buttons before operating this machine.

- Be familiar with the power off or disconnect procedure. This procedure includes turning off the power and locking the power disconnect switch in the off position.
- Always be aware of all moving parts and of the danger in putting hands or limbs in or around these areas.
- Note the high operating temperatures required in operating the glue system. Always wear gloves, goggles, and protective clothing when servicing the glue systems.

## Lockout Information

Never attempt to adjust, repair, clean, or remove cases in a jam condition without stopping, powering down, and locking the machine out.

### Main Power Panel

To lock out the power:

1. Push the red emergency stop button.
2. Rotate the disconnect switch to the “Off-Lock” position.
3. Under the disconnect switch, locate and push up the lock slide.
4. Insert a lock into the exposed squared area.
5. Test all buttons and try moving the switch to make sure power cannot be applied.

### Power Disconnect Switch

This switch must be in the ON position to operate the machine. Turn OFF when washing the machine or when making repairs or adjustments other than changeovers.

To open the control panel:

1. Twist the disconnect switch to the OFF position
2. Push down on the thumb switch (see figure 4, item 1) and slide the outer ring down
3. Pull open the door.

The power disconnect switch may be locked in the OFF position. To lockout the power, pull the black plastic bracket out from the handle and hook a padlock into the opening (in the off position only).

This prevents the power from being restored to the machine. For further instructions, refer to the documentation for the power lockout switch.

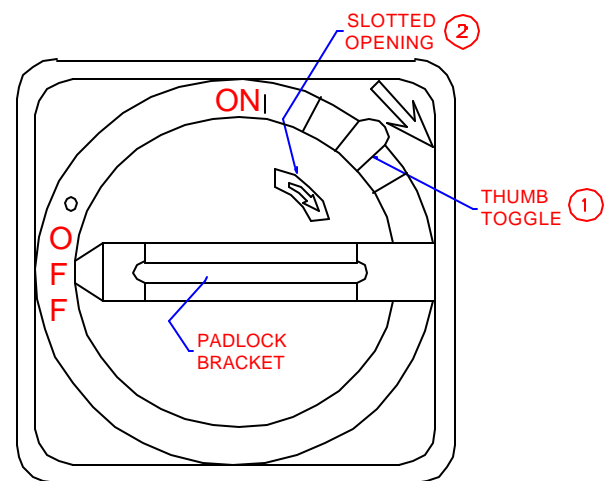

- ① OPENS DOOR WHILE DISCONNECT SWITCH IS IN THE OFF POSITION:  
 1) PUSH DOWN ON THUMB SWITCH  
 2) OPEN DOOR

## Safety Features

The 1T4K Traymatic has been built with safety as a prime consideration. To protect personnel from moving parts, wire mesh guards are installed front and rear, over the mandrel and feed wheel areas. All mesh guards are prewired to halt the Traymatic when they are removed or not secured properly. A flashing amber strobe light indicates the machine is powered up and operational. The red “E” stop switch located on the main power panel is of the push/pull type and must be manually operated. This power panel also contains the lockable disconnect lever.

*This page intentionally left blank.*

# Options

---

The following are available options for the SWF 1T 6K Traymatic. Contact SWF Machinery for information.

- Large capacity glue pots
- Time delay
- Down stream control systems
- Color coded wiring
- Left hand control box
- NEMA 4 power cabinet enclosures
- Hopper low level indicator
- Hopper empty cycle stop
- Bottom stop jam detector
- Pressurized hot melt systems
- Cold glue systems
- Code daters / Bar counters
- Adjustable elevated legs
- Special guarding
- Customized paint
- Additional manuals
- Horizontal powered hopper

### “V” Belt Vari-Drive Assembly:

Item	Qty	Part No.	Description
1	1	G3231*	PULLEY, VARI-DRIVE MOTOR..12-35 OR 21-58 SPEED
2	1	G3232	ARM, MOTOR DRIVE SPEED CONTROL
3	1	G3233	WASHER, MOTOR DRIVE BASE
4	1	G3235	ROD, SPEED CONTROL OPERATING
5	1	G3236	BASE, MOTOR DRIVE
6	1	GB145	BUSHING, SPEED CONTROL ARM SPACER 1 OD x 41/64 ID x 3/8 LONG
7	1	GB198	BUSHING, MOTOR PULLEY SPACER 7/8 OD 5/8 ID x 3/4 LONG
8	1	GB267	BUSHING, SPEED CONTROL OPERATING SPACER 13/16 OD x 21/64 ID x 3/8 LONG
9	1	GB271	BUSHING, SPEED CONTROL OPERATING ROD 1/2 OD x 21/64 ID x 25/32 LONG
10	1	GJ9D	KEY, VARI-DRIVE PULLEY
11	1	GM4B*	MOTOR, 3/4 H.P., 3 PHASE, 240/460V, 50/60HZ, 1800 RPM
		GM4D*	MOTOR, 3/4 H.P., 3 PHASE, 115/230V, 50/60HZ, 1200 RPM
12	1	GW1	WASHER, 1 OD x 7/16 ID x 5/32 THICK
13	1	GW56	WASHER, 3/4 OD x 5/16 ID x 1/8 THICK
14	1	-	1/4-20 NC x 3/8 LONG, SOCKET SET SCREW
15	3	-	3/8-16 NC x 3/4 LONG, FLAT HEAD ALLEN SCREW
16	1	-	7/16-20 NF HEX NUT

REFER TO MACHINE ORDER PART NUMBER

*"V" Belt Vari-Drive Assembly:*

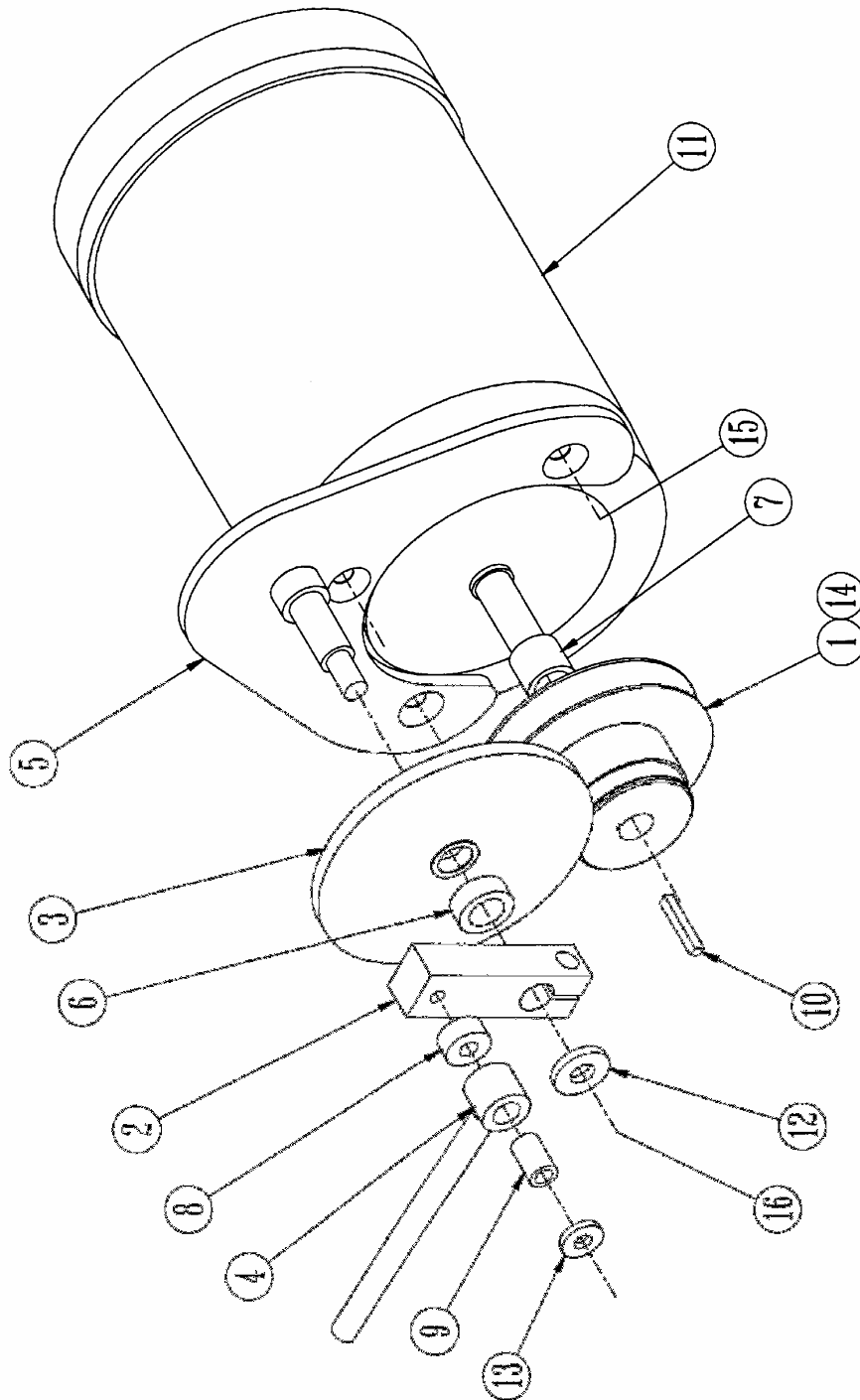

**"V" BELT VARI-DRIVE ASSEMBLY**

## Vari Speed Control Knob Assembly

Item	Qty	Part No.	Description
1	1	G3232	ARM, MOTOR DRIVE SPEED CONTROL
2	1	G3234	KNOB, SPEED CONTROL
3	1	G3235	ROD, SPEED CONTROL OPERATING
4	1	GA5	SET COLLAR, SPEED CONTROL ROD STOP
5	1	GA9	SET COLLAR, SPEED CONTROL ROD RETAINING
6	1	GB267	SPACER, SPEED CONTROL OPERATING ROD
			13/16 OD x 21/64 ID x 3/8 LONG
7	1	GB271	BUSHING, SPEED CONTROL OPERATING ROD
			1/2 OD x 21/64 ID x 25/32 LONG
8	1	GW56	WASHER, 3/4 OD x 5/16 ID x 1/8 THICK
9	1	-	#10-32 x 3/8 LONG, ROUND HEAD MACHINE SCREW W/FLAT WASHER
10	1	-	1/4 NC x 1/4 LONG, SOCKET SET SCREW
11	1	-	5/16 NC x 5/16 LONG, SOCKET SET SCREW
12	1	-	5/16 NC x 1 3/4 LONG, HEX HEAD CAP SCREW
13	1	-	3/8 NC x 1 LONG, SOCKET HEAD CAP SCREW

NOTE: These parts may be purchased as a preassembled package. To order, specify BU176.

Vari Speed Control Knob Assembly

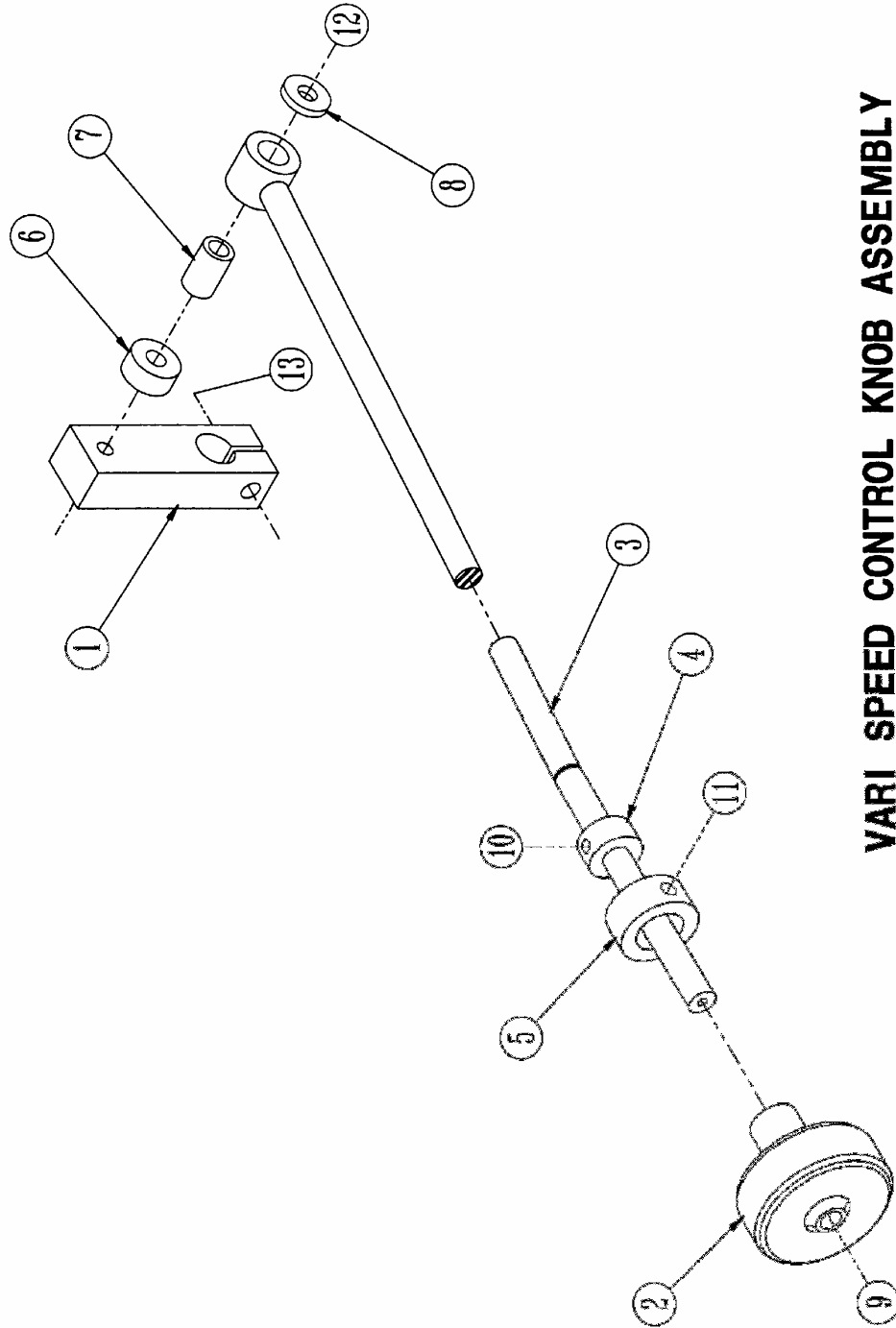

**VARI SPEED CONTROL KNOB ASSEMBLY**

### Large Capacity Glue Pot (Kwik-Change)

Item	Qty.	Part No.	Description
1	1	G3089B	CASTING, ADHESIVE MELT POT
2	2	G7121	STRIP HEATER
3	1R/1L	G7125A	BASE, ADHESIVE MELT POT
4	1R/1L	G7126A	BASE, ADHESIVE MELT POT ( REAR )
5	2	G7127	PLATE, STRIP HEATER CLAMP
6	4	G7129	WASHER, ADHESIVE MELT POT MTG. FEET
7	1	G7131	END CAP, ADHESIVE MELT POT SHROUD
8	1	G7135A	PLATE, BOTTOM ENCLOSURE SHROUD
9	4	G7574	WASHER, INSULATING
10	4	G7575	BUSHING, POT INSULATING
11	1R/1L	G7576B	BRACKET MOUNT, LARGE CAPACITY GLUE POT
12	1	MTO	BAR, BRACKET
13	1R/1L	G8246	MOUNT, ADHESIVE SYSTEM MOUNTING BRACKET
14	2	G8414	MOUNTING BRACKET, LARGE MELT POT
15	3	GB20	BUSHING
16	1	GB189	BUSHING
17	3	GB262	SPACER (WHEEL)
18	4	GB396	BUSHING (SPACER)
19	3	GW56	WASHER
20	3	GW66	WASHER

Large Capacity Glue Pot (Kwik-Change)

