

CL SERIES

Case Loaders

Machinery Specifications:

Utilities Required:

Electrical: 230/460 Volts, 3 Phase, 60 Hz
Air: 60-70 PSI

To learn more about the CL Series and SWF Companies' broad line of forming, erecting and sealing solutions for secondary packaging, case/tray packing systems, horizontal/vertical cartoners and robotic packaging solutions, please visit our website at www.swfcompanies.com

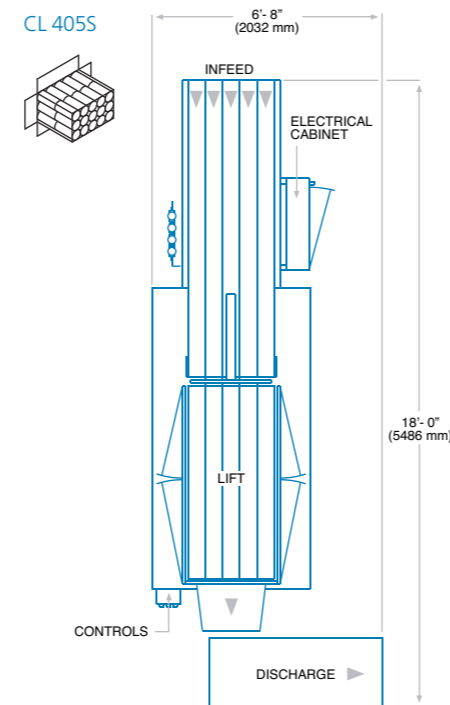
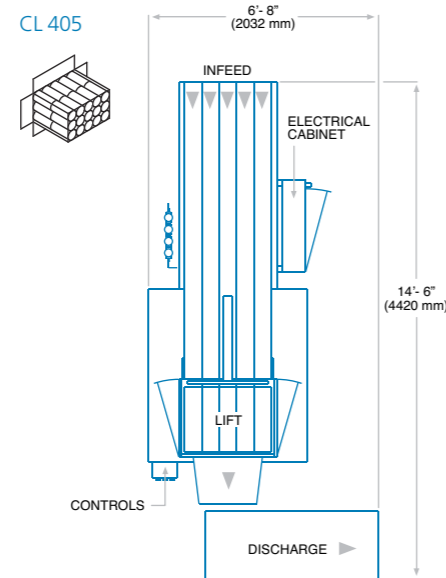
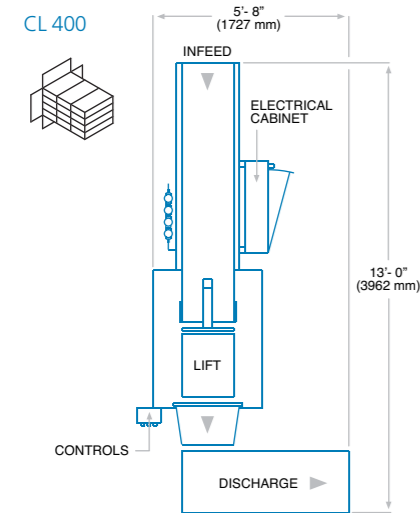
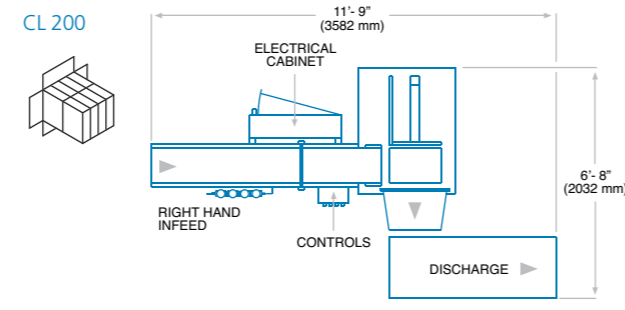
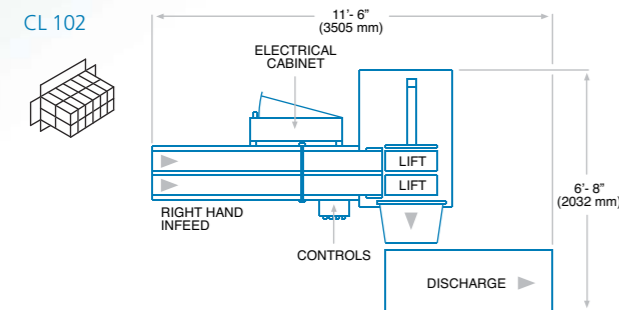

CL SERIES

Case Loaders



Convey, Position, Accumulate and Load up to 30 Cases Per Minute

- Flexible
- Customized Designs
- Full Operator Safety
- Modular Design
- Quick Changeover
- Low Maintenance



www.swfcompanies.com | 800.344.8951 | info@swfcompanies.com



A DOVER COMPANY

CL SERIES

Case Loaders

CL Case Loaders

SWF Companies' CL models are modular case loaders designed to convey, position, accumulate and load various packages into corrugated shipping cases. Each CL model is customized to fit a specific application and all models can be easily integrated with various SWF case opener/sealer models to form fully automatic case packing systems, capable of reaching speeds of up to 30 cases per minute. An operator is required to open and place the cases on the semi-automatic models, while the actual loading of the case is completely automatic.

SWF's CL models will load virtually any product that is packaged in a rigid or semi-rigid container. Typical applications include paper products, cereal, baked goods, detergents, cosmetics, pharmaceuticals, confectionery products, general food products and a host of other items.

Standard Features:

- Up to 30 Cases Per Minute
(15 cases per minute for semi-automatic systems)
- Modular Design
- Quick Changeover
- Full Operator Safety
- Rugged Construction
- Customized Designs
- Low Maintenance
- Allen Bradley Controls

Available Options:

- Touch Screen Operator Interface with Multiple Screens and Message Panels
- Servo-Controlled Operation
(standard on staging ram of CL 100C case loader)
- Centralized Grease Blocks or Lubrication Systems
- Various Product Handling Devices, Including Converging, Diverging, Accumulating and Positioning Devices
- Automatic Insert Feeders for Corrugated Dividers
- PLC Controls for Easy Trouble Shooting and Line Communications
- Many Other Features and Options are Available to Customize a Machine to Meet Individual Requirements

Available Models:

- CL 100SW**
Single lane, slow speed case loader
- CL 100**
Single lane, medium speed, case loader
- CL 100C**
Single lane, high speed, case loader with servo-controlled product staging ram
- CL 100S**
Single lane, high speed case loader with staggered product accumulation system
- CL 102**
Dual lane, medium speed case loader
- CL 200**
Single lane, medium speed case loader for case patterns requiring no product stacking
- CL 400**
Single lane, medium speed case loader for in-line operation
- CL 405**
Multi lane, medium speed case loader for handling roll paper products such as toilet paper or household towels
- CL 405S**
Multi lane, high speed case loader with staggered product accumulation system for handling roll paper products



CL 100SW
Compact Semi-Automatic Case Loader



CL 405
Medium Speed Inline Case Loader

Basic Machine Operation:



Rolls of paper product, in multiple lanes, feed into the CL 405.



Accumulated rolls are stacked prior to loading into the awaiting case.



Case is opened and placed on the case packer loading tube by an operator.



Loaded case is conveyed to customer's top and bottom sealer.

Machinery Specifications:

Utilities Required:

Electrical: 230/460 Volts, 3 Phase, 60 Hz
Air: 60-70 PSI

