

PL 200 PIVOT LOADER

Vertical Packing for Stand-Up Pouches

- Up To 150 Units Per Minute
- Infeed Product Settler
- Packs Into Bliss, Tray or RSC
- Minimal Space Requirement
- Portable
- Numerous Pack Patterns



PL 200 PIVOT LOADER

Formerly the Pouch Packer

Standard Features:

- Product Settler/Conveyor
(vibrates product/provides flat uniform bag)
- Case Discharge Pusher
(discharges filled case onto take-away conveyor)
- PLC (various makes and models available)
- Case Holder
(supports empty case in loading position)
- Touch Screen Operator Interface
(control switches easily accessible to operator)
- Polycarbonate Interlocked Guard Package

Available Options:

- 90 Degree Bag Turner
- 180 Degree Bag Tipper
(reduces case size for wedge shaped product)
- Broken Bag Detector
- Automatic Case Positioner
(positions pre-formed case in loading station)
- 90 Degree Rotating Buckets
- Line Integration (available upon request)
- Call for additional options

OPERATING SEQUENCE

Pivot Loading / Pouch Packing Sequence

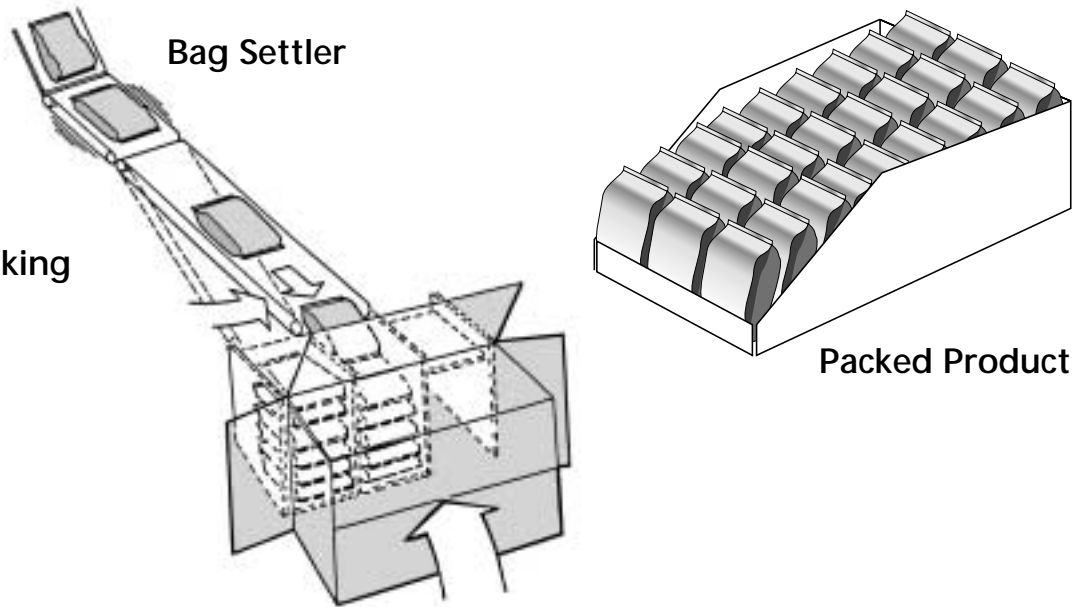

Pack Patterns:

2 to 4 Columns Wide
2 Deep
Up to 25 Bags/Cartons Long

MACHINERY SPECIFICATIONS

Several Configurations Available:

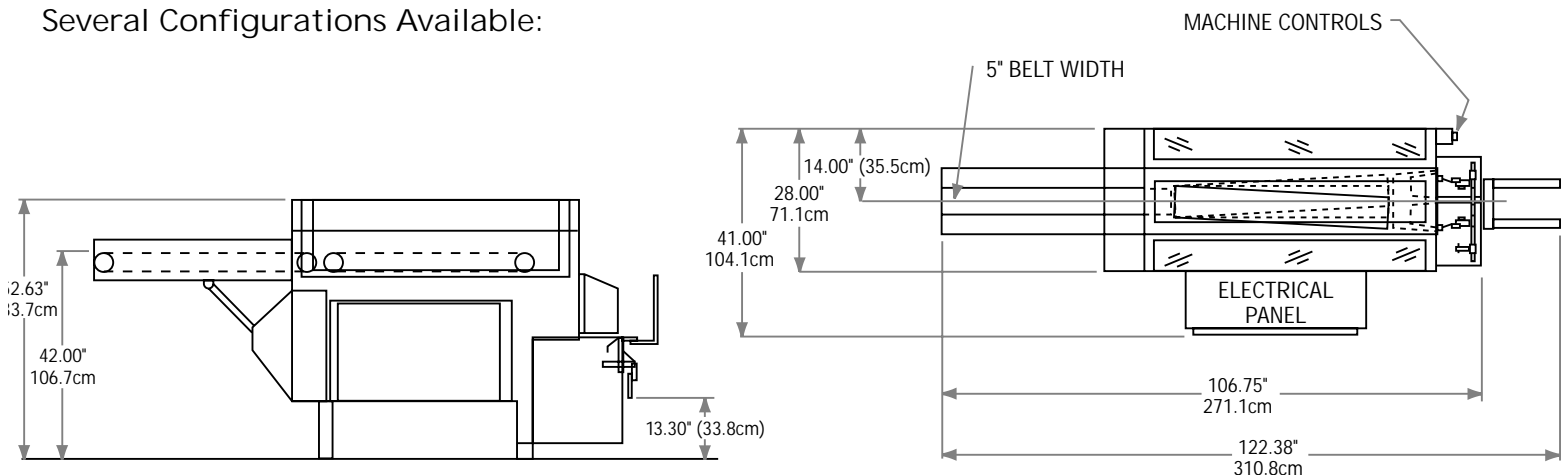

900 East Chemical Drive • P.O. Box 6820 • Kennewick, WA 99336
 Phone: (509) 586-2105 • Fax: (509) 582-4519 • Toll Free USA: (800) 228-3962
 E-mail: swfnw@swfcompanies.net • Web Site: www.swfcompanies.com

