

APPLICATION & DESIGN

Bulletin



Volume IV, Issue 11

November 2004

QUICK FACTS

- **Solution:** TF 400H
- **Speed:** Up to 45 trays per minute
- **Industry:** Various
- **Application:** Horizontal tray forming
- **Design:** Numerous styles, including common footprint, corner post, diagonal corner, roll-side, etc.

PRIMARY PACKAGING

SWF Companies—Tisma Division
1099 Estes Ave.
Elk Grove Village, IL 60007

Phone: 847-427-9525
Fax: 847-427-9550

SECONDARY PACKAGING

SWF Companies
1949 E. Manning Avenue
P. O. Box 548
Reedley, CA 93654

Phone: 559-638-8484
Fax: 559-638-7478

ROBOTICS

SWF Companies—GSMA Division
2730 Kirby Ave., NE Building #5
Palm Bay, FL 32905

Phone: 321-728-3800
Fax: 321-728-5555

info@swfcompanies.com
www.swfcompanies.com

New SWF Horizontal Tray Former Brings Modularity to the Forefront

As SWF Companies looks towards the future, with a keen awareness of our customer's expectations, several common themes continue to emerge. Simple, affordable, fast delivery and ergonomically friendly (SAFE) packaging solutions are what our customers continually search for.

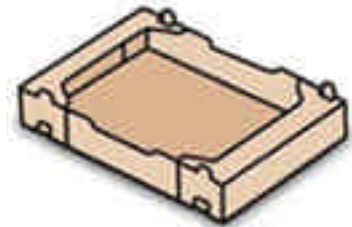

Double-Corner (BTB) Trays

In keeping with our desire to produce SAFE packaging automation solutions and respond to our customer's needs, SWF is excited to offer the new TF 400H horizontal tray former.

While horizontal tray formers have been on the market for many years, the design of the TF 400H makes it vastly different from competitive product offerings. Modular in design and construction, the TF 400H allows customer's to mix-and-match features which are required for their specific application. No more "one size fits all" approach, as each "module" can work independently from the others. Only those required to produce the desired tray, become part of the TF 400H.

Often accommodating larger tray blank sizes, when compared to vertical forming solutions, the TF 400H is capable of reaching speeds up to 45 trays per minute. Utilizing either servo or pneumatic technology,



Continued on Next Page....

Innovative Packaging Automation

Continued From Previous Page....

again the customer's choice, the TF 400H is offered at a variety of price points and levels of sophistication.

While there are several modules to choose from, depending on the tray style, each TF 400H is typically comprised of a feeder module and forming module. A laminating module is available (shown

below) for corner post, roll side and diagonal corner tray styles.

Another key to the modularity concept, is that each TF 400H can be reconfigured with new modules, to run new tray styles. A new machine is no longer required, as the bolt-on modules are easily removed and reconnected.



**Common Footprint
Trays**



**Corner Post
Trays**



**Diagonal Corner
Trays**



**Roll-End/Roll-Side
Trays**

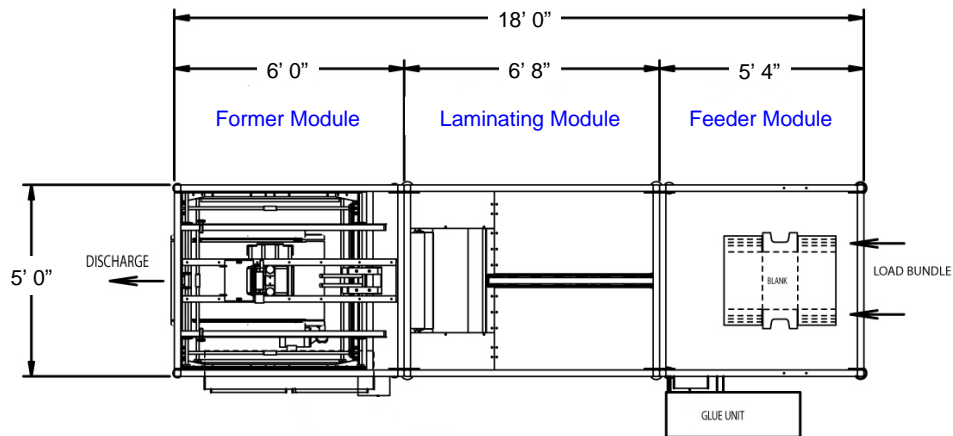

PLAN VIEW

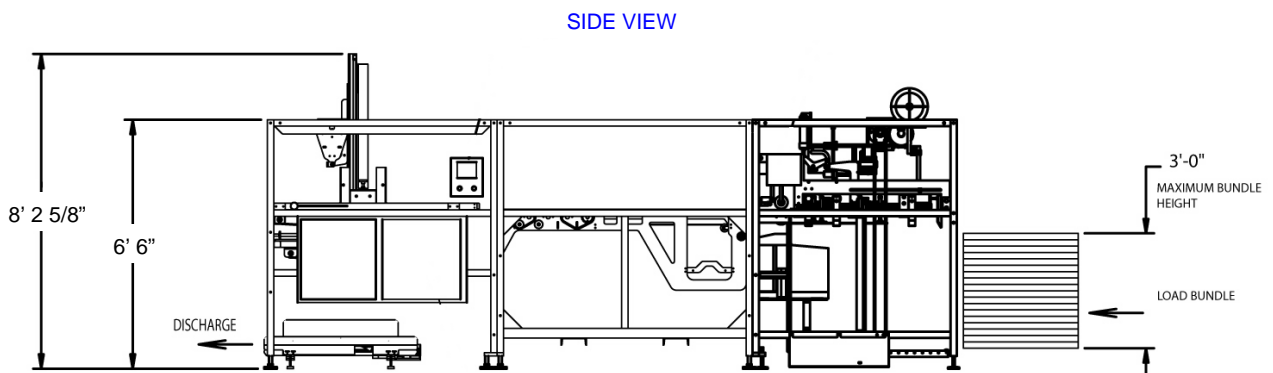

SIDE VIEW



Volume IV, Issue 11 November 2004

The Application & Design Bulletin is published monthly by SWF Companies, Reedley, CA. If you have any comments or suggestions regarding the Application & Design Bulletin, please contact Joel Anderson or email us at info@swfcompanies.com.

www.swfcompanies.com