

VL 480

Case/Tray Lidder



**Forms and Seals Lids onto Filled Cases/Trays
in One Continuous Motion**

- Up to 25 Cases/Trays Per Minute
- Allen Bradley Components
- Mechanical Simplicity
- Heavy Duty Construction
- Compact Footprint



VL 480

Case/Tray Lidder

Standard Features:

- Pressurized Hot Melt Glue Unit
- Gravity Roller Case Discharge
- Programmable Logic Controller - Control Switches Easily Accessible to Operator
- Polycarbonate Interlocked Guard Package

Available Options:

- Multiple Case Size Adjustment Features - Used For Multiple Tray Sizes
- 2 Sided, 4 Sided or DST Style Lids
- Case Pass-Thru Capability
- Random Case Height Capability
- Quick-Change Features

To learn more about the VL 480 and SWF Companies' broad line of forming, erecting and sealing solutions for secondary packaging, caseltray packing systems and horizontal/vertical cartoners, please visit our website at www.swfcompanies.com

Typical Lidding Configurations:

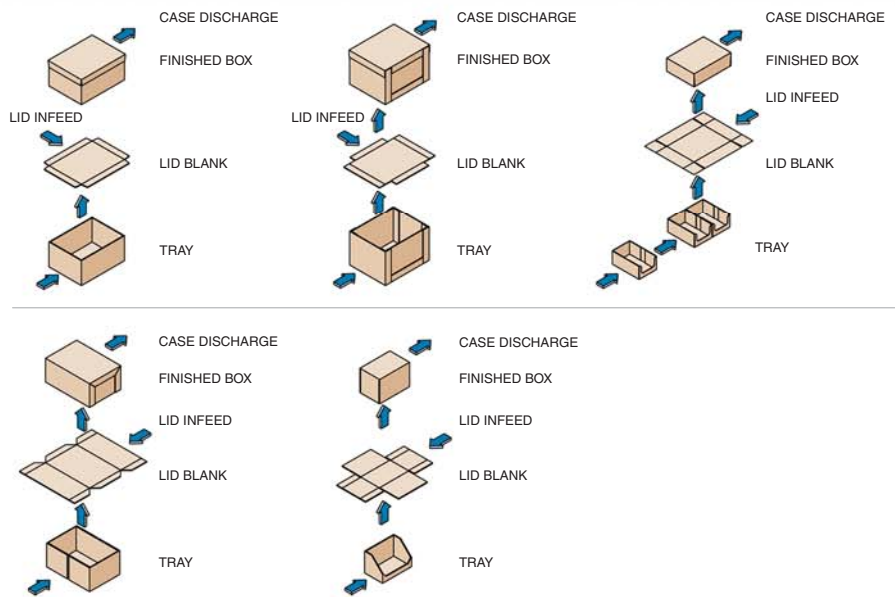

Machinery Specifications:

Utilities Required:

Electrical: 460 Volts, 3 Phase, 60 Hz
Air: 15 CFM @ 80 PSI

Footprint & Operating Sequence:

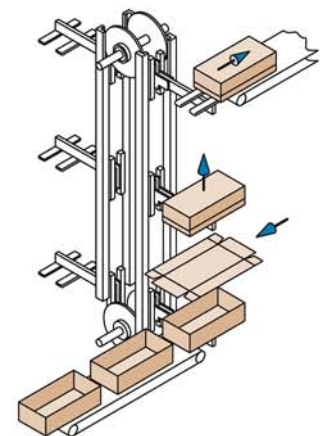
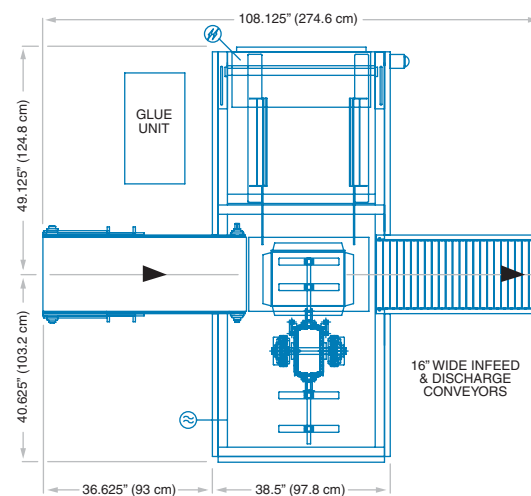

www.swfcompanies.com | 800.344.8951 | info@swfcompanies.com

